



**SINGLE COMPARTMENT-FULL SIZE
ROLL-IN TYPE-GAS-FIRED
COMBI OVEN / STEAMER**

General Specifications :

- Multi-Purpose Oven offers Pressureless Convection cooking in a variety of cooking modes; featuring Automatic Reversible Fan operation for superior Convection Cooking.
 - Hot Air Convection.
 - Pressureless Convection Steamer.
 - Combination of Convection Steamer and Hot Air.
- Reliable, easy to operate mechanical controls feature:
 - One 100-minute Mechanical Dial Timer Control.
 - One 125-500 C° degree Mechanical Dial Temperature control.
 - One Mechanical Dial Control for three modes of cooking operation; Hot Air, Steaming or Combi.
- User-friendly control panel has many standard features for superior cooking performance.
 - On/Off Switch for externally mounted oven lights.
 - Automatic Fast Cool Down Control.
 - Two-Speed Fan (High/Low) control switch.
 - Humidity Release Control Switch removes excess moisture from compartment.
 - Generator Drain Control.
- Core-Temperature Probe with Digital Read-Out automatically turns off unit when desired temperature is reached.
- Each Compartment has Ten Stainless Steel Wire Shelves.
- Fully-insulated Cooking Compartment and Steam Generator for thermal efficiency. Easy to clean Die Pressed interior compartment features a Coved Corner design.
- Heavy Gauge Stainless Steel Gas-Fired Steam Generator with 150,000 BTU Power Rating features an easy Access Delimiting Port and Electronic Spark Ignition for easy start-up. Reliable Electronic Controls monitor Water Level and Safety Functions in steam generator.
- One Removable Stainless Steel Oven Rack Cassette. Can be used with optional Transport Cart.
- Standard with Adjustable Left-Hand Door Hinging and Large Glass Window to observe cooking operation. Removable Double Door Gasket Seal prevents leaking. Safety Switch stops fan when compartment door is opened.
- Compartment Door Condensate Drip Tray automatically empties into floor drain.
- NSF Approved 11" Stainless Steel Adjustable Legs: provides one inch level adjustment.
- Standard voltage for controls is 115 volts, 60 Hz, single phase.
- Each compartment has the capacity for:
 - Forty-six, 13" x 18" U.S. Bake Pans.
 - Twenty-two, 12" x 20" x 2½" Steam Table Pans.
 - Twenty-three, 18" x 26" U.S. Bake Pans.

MODEL: MG-220X



MODEL AVAILABLE

Shall be BURLODGE/LAINOX Combi Oven, Floor Model Roll-in Type Multi-Purpose Oven, Model MG - 220X for _____ gas operation, _____ volts, _____ Hz, _____ phase. Cooking modes for: Hot Air Convection, Hot Air Convection with Water Injection; Low and High Temperature Convection Steam; combination of Hot Air and Steam; Core Temperature Probe; variable Steam Exhaust Condensation Control; and Butterfly Valve to regulate humidity exhaust.

Options and Accessories:

- Transport Cart Model (CS-2200)
- Additional Oven Rack Cassette Model (SG-220)
- Mobile Oven Rack Floor Stand Model (TS-220)
- Grease Filter Model (FX-220)
- Additional Stainless Steel Wire Shelves
- Steam Table Pans in depths of 1", 2½" or 4"
- Spray Hose with 60" Flexible Hose for Cleaning (SH-60)
- Dissolve® Liquid Descaling Kit (10617413)
- Correctional Packages
- Accessories for handling and transportation compatible with Blast Chillers/Freezers

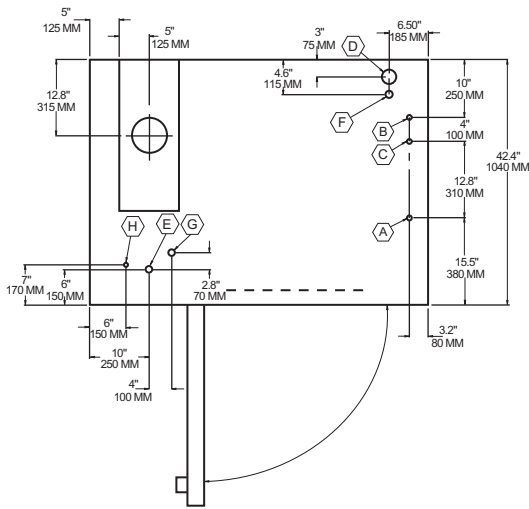

- Compartment has capacity for:
 - 46 — 12" x 20" Wire Shelves or
23 — 18" x 26" Wire Shelves
 - 46 — 12" x 20" x 1" Cafeteria Pans or
23 — 12" x 20" x 2½" Cafeteria Pans or
23 — 18" x 26" Bun Pans
- Many local codes exist and it is the responsibility of the owner and installer to comply with those codes.
- **Burlodge / Lainox** equipment is built to comply with applicable standards for manufacturers. Included among those approval agencies are: UL, A.G.A., NSF, ASME/N.Bd., CSA, CGA, ETL, and others.

WATER QUALITY REQUIREMENT

The recommended minimum water quality standards whether untreated or pre-treated, based upon 10 hours of use per day, and a Daily Blowdown, are as follows:

TOTAL DISSOLVED SOLIDS	less than	∅	60 parts per million
TOTAL ALKALINITY	less than	∅	20 parts per million
SILICA∅	less than	∅	13 parts per million
CHLORIDE∅	less than	∅	30 parts per million
pH FACTOR∅	greater than	∅	7.5

Consult a local water treatment specialist for an on-site water analysis for recommendations concerning steam generator feed water treatment (if required), in order to remove or reduce harmful concentrations of minerals. The use of highly mineralized water will mean that more frequent servicing of the steam generator will be necessary. The fact that a water supply is potable is not proof that it will be suitable for the generator.

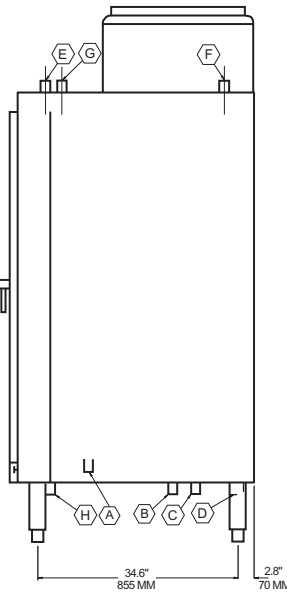
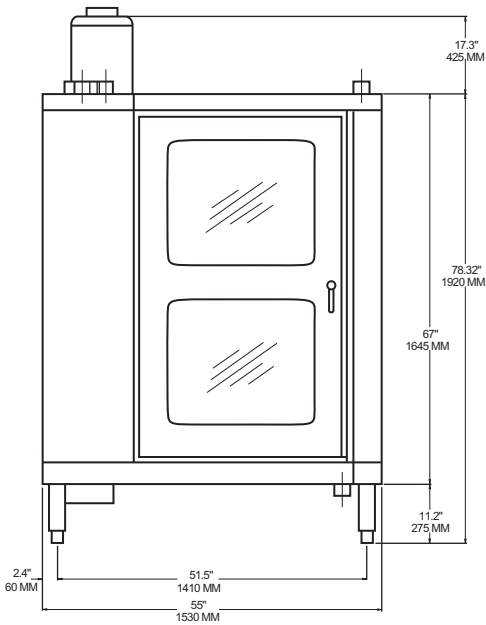

UTILITY CONNECTIONS

- A = ELECTRIC CONECTION**
- BOILER **B = COLD WATER INLET 3/4" NHT.**
- CONDENSER **C = COLD WATER INLET 3/4" NHT.**
- D = DRAINAGE 2.50" DIA (64 MM)**
- E = DESCALER INLET**
- F = WASTE AIR OUTLET
1.18" DIA (30 MM)**
- G = CHAMBER WASTE AIR OUTLET**
- H = GAS CONNECTION 3/4" NHT.**
- I = EXHAUST CHIMNEY HOT AIR**
- J = EXHAUST CHIMNEY BOILER**
- K = EXHAUST MANIFOLD**

SHIPPING WEIGHT	= 1168 Lbs.
MAX. WATER CONSUMPTION PER HR. STEAM PRODUCTION	= 7.7 Gal./Hr
AVERAGE WATER CONSUMPTION PER HR. STEAM CONDENSER	= 6.6 Gal./Hr
TOTAL WATER CONSUMPTION	=14.3 Gal./Hr

MODEL	GAS	ELECTRIC (3 PH)	WATER	DRAINAGE (D)	CLEARANCE																		
MG - 220X ONE COMPARTMENT ROLL-IN TYPE GAS-FIRED	<table border="1"> <tr> <th>(BTU)</th> <th>SUPPLY PRESSURE</th> </tr> <tr> <td>HOT AIR 136,000</td> <td>NATURAL</td> </tr> <tr> <td>BOILER 150,000</td> <td>4.50" W.C. MINIMUM 14.00" W.C. MAXIMUM</td> </tr> <tr> <td>COMBI 229,000</td> <td>PROPANE</td> </tr> <tr> <td></td> <td>11.00" W.C. MINIMUM 14.00" W.C. MAXIMUM</td> </tr> </table> <p>MANUFACTURER MUST BE NOTIFIED IF UNIT WILL BE USED ABOVE 2,000 FT. ALTITUDE</p>	(BTU)	SUPPLY PRESSURE	HOT AIR 136,000	NATURAL	BOILER 150,000	4.50" W.C. MINIMUM 14.00" W.C. MAXIMUM	COMBI 229,000	PROPANE		11.00" W.C. MINIMUM 14.00" W.C. MAXIMUM	<table border="1"> <tr> <td>ELECTRICAL DATA</td> <td>115/60/1</td> </tr> <tr> <td>MINIMUM WIRE AMPACITY (AMPS)</td> <td>35</td> </tr> <tr> <td>MAXIMUM TIME DELAY FUSE</td> <td>35</td> </tr> <tr> <td>MAXIMUM TIME DELAY FUSE</td> <td>25</td> </tr> </table>	ELECTRICAL DATA	115/60/1	MINIMUM WIRE AMPACITY (AMPS)	35	MAXIMUM TIME DELAY FUSE	35	MAXIMUM TIME DELAY FUSE	25	35 PSI MINIMUM 60 PSI MAXIMUM ∅ 3/4" NHT (GARDEN HOSE) FOR BOILER & CONDENSER	2.50" DIA. (64 MM) DO NOT CONNECT ANY OTHER UNITS TO THIS DRAIN DRAIN LINE MUST BE VENTED	RIGHT = 6" LEFT = 6" REAR = 7" NOTE: 12" RIGHT SIDE CLEARANCE IS REQUIRED IF PLACED NEXT TO HEAT SOURCE
(BTU)	SUPPLY PRESSURE																						
HOT AIR 136,000	NATURAL																						
BOILER 150,000	4.50" W.C. MINIMUM 14.00" W.C. MAXIMUM																						
COMBI 229,000	PROPANE																						
	11.00" W.C. MINIMUM 14.00" W.C. MAXIMUM																						
ELECTRICAL DATA	115/60/1																						
MINIMUM WIRE AMPACITY (AMPS)	35																						
MAXIMUM TIME DELAY FUSE	35																						
MAXIMUM TIME DELAY FUSE	25																						

BURLODGE/LAINOX reserves right of design improvement or modification, as warranted.

BURLODGE™

BURLODGE CANADA LTD
10, EDVAC DRIVE
BRAMPTON
ONTARIO L6S 5P2
CANADA
TEL. 905 790.1881
TOLL FREE: 1 888 609.5552
FAX 905 790.1883
E-mail: info@burlodgeca.com
www.burlodgecanada.com

BURLODGE CANADA LTEE
5995 boul. GOUIN OUEST
BUREAU B-305
MONTREAL, QUEBEC H4J 2P8
CANADA
TEL. 514 339.5552
TOLL FREE: 1 888 609.5552
FAX. 514 339.2555
E-mail: infoquebec@burlodgeca.com
www.burlodgecanada.com

BURLODGE USA Inc.
P.O. BOX 4088
3760 INDUSTRIAL DRIVE
WINSTON - SALEM
NORTH CAROLINA 27115 - USA
TEL. 336 776 1010
TOLL FREE: 1 877-REThERM
FAX 336 776 1090
E-mail: info@burlodgeusa.com
www.burlodgeusa.com



ASSOCIATED COMPANIES
BURLODGE GREAT BRITAIN
BURLODGE ITALY
BURLODGE FRANCE
BURLODGE HOLLAND
BURLODGE BELGIUM