



BURLODGE

U.S.A.

United Kingdom

Italy

Canada

Belgium

Export



RTS

READY
TO
SERVE

ACTIVE TEMPERATURE
MAINTENANCE AND
TRAY DISTRIBUTION SYSTEM

- Cook Serve/
Hot Line
- High Food
Safety
Standards



READY TO SERVE



Optional 6 wheel configuration



When your demands are hot foods hot and cold foods cold being served to your clients, Ready To Serve (RTS) is today's new answer.

The Ready To Serve supports hot line/cook serve preparation of trays and provides an effective way to transport and distribute hot and cold patient meals. This new and innovative state of the art system promotes quality outcomes and high standards of food safety.

The RTS helps your staff deliver ready to serve meals at the right temperatures while using ergonomically safe equipment that is both flexible in application and simple to operate.

The Ready To Serve – Burlodge Manufacturing Excellence Continues

The RTS is constructed using a combination of 304, 18/10 stainless steel and ABS Thermo Plastic material, making it strong and durable as well as easy to move throughout your facility.

The RTS is manufactured in a unique way that guarantees that all electrical and mechanical components are readily accessible facilitating preventative maintenance programs and repairs. Burlodge manufacturing conforms to Environment System Standards ISO 14001 and ISO 9001.

Unique Benefits and Applications

- Heating and hot holding of foods is accomplished by using thermo-convection designed to circulate hot air throughout the oven side of the RTS. This allows for longer hot temperature holding periods. Cold food items remain cold through the use of a forced air refrigeration system. Hot and cold foods can be maintained at correct serving temperatures inside the same cart on the same patient tray.
- With the RTS you can use any type of dishware such as china, high heat plastics, single use (disposables), or high temperature paper products.
- The RTS has two doors that fold back 270 degrees allowing the operator easy and quick access to both sides of the cart and all trayed meal components (both hot and cold).
- The RTS digital control panel is easy to see when the doors are open or closed.
- The side panels and the top of the cart are made of ABS thermoplastic that is strong, long-wearing, and resistant to stains and chemicals, giving the cart a pleasing appearance.
- The RTS is available in four tray capacity sizes: 20, 24, 26, or 30.
- Two (2) lateral stainless steel handles allow safe and easy movement of the cart by food service staff.
- The RTS is protected by bumpers that surround the base of the cart and the cart is fully welded, using 304 #4 18/10 stainless steel.
- The flat tray has no ridges, holes, or recesses and is reversible and stackable – available in three (3) colors – beige, orange and pastel green – and two sizes.
- The divider wall separates the cold and hot sides of the RTS and can be easily removed to facilitate cleaning. It can also be removed completely and wire stainless steel supports put in place to create shelving so that the cart can be used for cold holding of bulk or portioned foods.
- Options include:
 - A guard rail on the top of the unit to support the transport of other items such as floor stocks, nourishments, and bread baskets.
 - A six wheel configuration to improve push/pull factors in challenging environments such as carpeted floors, slopes, and tight corridors.
 - A tow bar to facilitate multiple cart delivery using a motorized towing system.



On One Tray – Two Different Temperatures Single handling makes you Ready To Serve with style and ease.

Inside the Ready To Serve there is a divider wall that completely separates the hot from the cold side of the tray. You demand hot holding and cold holding of food and the RTS delivers. Your expectations are further enhanced with your choice of tray size. You can use a large style flat tray (22 ⁵/₈" x 12 ³/₄") or you can use a smaller size flat tray (21" x 12 ³/₄").

The tray slides into the divider wall in a way that immediately guarantees the separation of the tray components and keeps your foods at the right serving temperature. When you are ready to serve your clients, the Burlodge RTS is ready to serve you with a tray that is simply removed in one motion and presented with a smile.



BURLODGE



The Ready To Serve Burlodge Difference... it's not a tray – it's a meal

Attractive tray presentation

The Burlodge flat tray can be personalized to each client's needs. Furthermore, the surface area of the tray and the methods of heating and cooling provide each food service expert an opportunity to create a complete meal that is pleasing to see, easy to enjoy, and tempting to each individual and their specific need...it's not a tray – it's a meal.



*A flexible solution
for every requirement*



Simplicity of operation

The RTS takes care of keeping food hot and foods cold. It is easy to use. Staff are trained quickly and are rewarded when their clients receive hot foods hot and cold foods cold. The two (2) doors allow simplified operation and ease of accessibility.



The cart itself takes up a small footprint and is easily sanitized.

Respect for hygiene and safe food handling

The divider wall can be removed completely or partially for deep cleaning or simple maintenance. It can also be easily removed for washing and sanitizing at any time.



Simplistic digital control panel with ready to program functions

- On and Off touch pads
- Three temperature holding cycles with programming of the hot and cold sides of the RTS
- Alternate reading of the temperatures in the hot and cold cavities of the cart
- Audible alarm signals the end of meal cycle



Personalization of trays

Patient trays can be enhanced by the use of high quality china. A wide assortment of shapes and sizes with attractive reusable lids are available to coordinate with all your menu needs. Burlodge China is available in four colors, including classic white.



RTS Ready To Serve

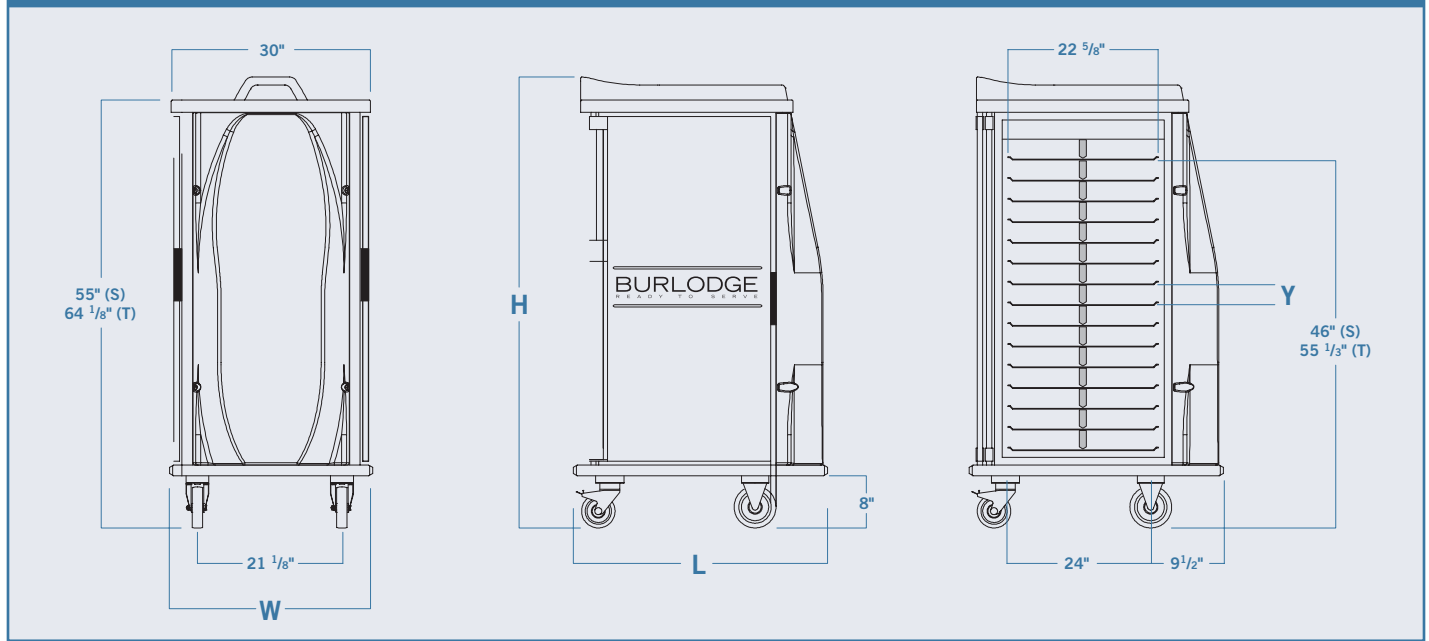

RTS Ready To Serve

REFERENCE	DESCRIPTION – SINGLE PHASE – NEMA L6-20	Tray Spacing Y inches	ELECTRICAL SPECIFICATIONS				DIMENSIONS			
			Total		Refrigeration only		H inches	L inches	W inches	
			AMPS	MAX kW	AMPS	kW				
SOS.500	20	RTS Short with integrated single refrigeration - single phase - 208V - 60 Hz - 2P+G	3 5/8"	16	3,1	5,0	1,0	58 5/8"	38 3/8"	30 5/8"
SOS.700	24	RTS Short with integrated single refrigeration - single phase - 208V - 60 Hz - 2P+G	3"	16	3,1	5,0	1,0	58 5/8"	38 3/8"	30 5/8"
SOT.500	26	RTS Tall with integrated single refrigeration - single phase - 208V - 60 Hz - 2P+G	3 5/8"	16	3,1	5,0	1,0	67 1/2"	38 3/8"	30 5/8"
SOT.700	30	RTS Tall with integrated single refrigeration - single phase - 208V - 60 Hz - 2P+G	3"	16	3,1	5,0	1,0	67 1/2"	38 3/8"	30 5/8"

RTS Ready To Serve

REFERENCE	DESCRIPTION – THREE (3) PHASE – NEMA L15-20	Tray Spacing Y inches	ELECTRICAL SPECIFICATIONS				DIMENSIONS			
			Total		Refrigeration only		H inches	L inches	W inches	
			AMPS	MAX kW	AMPS	kW				
SOS.500	20	RTS Short with integrated single refrigeration - three phase - 208V - 60 Hz - 3P+G	3 5/8"	20	6,2	5,0	1,0	58 5/8"	38 3/8"	30 5/8"
SOS.700	24	RTS Short with integrated single refrigeration - three phase - 208V - 60 Hz - 3P+G	3"	20	6,2	5,0	1,0	58 5/8"	38 3/8"	30 5/8"
SOT.500	26	RTS Tall with integrated single refrigeration - three phase - 208V - 60 Hz - 3P+G	3 5/8"	20	6,2	5,0	1,0	67 1/2"	38 3/8"	30 5/8"
SOT.700	30	RTS Tall with integrated single refrigeration - three phase - 208V - 60 Hz - 3P+G	3"	20	6,2	5,0	1,0	67 1/2"	38 3/8"	30 5/8"

Trays

REFERENCE	DESCRIPTION	DIMENSIONS
		L x W inches
S00.000	01 RTS Single Tray Beige	22 5/8" x 12 3/4"
	02 RTS Single Tray Pastel Green	
	03 RTS Single Tray Pastel Orange	
S00.000	30 RTS Single Tray Beige	21" x 12 3/4"
	32 RTS Single Tray Pastel Green	
	34 RTS Single Tray Pastel Orange	

Accessories

REFERENCE	DESCRIPTION
SOA.300	Top barrier
SOA.320	Lateral shelf
SOA.340	Destination tag holder
SOA.360	6 wheels kit
S00.380	Tow bar
SOA.400	Locking device with key



BURLODGE USA, Inc.
3760 Industrial Drive
Winston-Salem, NC 27115
1-877-REThERM
info@burlodgeusa.com
www.burlodgeusa.com

REGIONAL OFFICES

DALLAS
dallas@burlodgeusa.com
Phone: 214-697-6824
Fax: 972-304-3318

PHOENIX
phoenix@burlodgeusa.com
Phone: 602-549-4804
Fax: 413-473-6726

PHILADELPHIA
philadelphia@burlodgeusa.com
Phone: 484-433-9633
Fax: 610-666-9519

NASHVILLE
nashville@burlodgeusa.com
Phone: 615-309-7053
Fax: 615-309-8370

OTHER DIVISIONS

BURLODGE BELUX
BURLODGE CANADA
BURLODGE SRL ITALY
BURLODGE LTD UK
BURLODGE EXPORT